

Star-delta relay

Timer YDE timetron®

Timer YDC timetron®

with relay output



YDE-Screw connection



YDC Spring connection

- Delay on operate
 - Delay on release without auxiliary voltage
 - Especially for star-delta changeover
 - 2 time ranges for a variable start-up
 - 1 SPDT contact
 - 2 LEDs to indicate operational status
 - 2 voltage versions
- 24 V AC/DC / 220...240 V AC or 110...130 V AC

Operation

The YDE/ YDC is designed especially for starting-up squirrel cage motors by a star-delta starter. If the supply power is connected, the star connector (K1) is energized and the set start-up time starts to elapse.

The supply voltage contactor (K2) is switched in by the auxiliary contact of the star contactor (K1) and changes to self-latching by its auxiliary contacts 13/14.

Simultaneously the auxiliary contacts 21/22 of the supply voltage contactor (K 2) are opening, so the star-delta timer and the star contactor with its auxiliary contacts 43/44 are connected to supply power.

After the start-up time has elapsed, the star-delta timer interrupts this voltage line and disconnects itself and the control contactor (K1) from the supply. To enable a reliable de-energizing of the control contactor (K1), the contact 15/16 of the star-delta timer stays open for approx. 50 ms and then resets again.

The auxiliary contacts 22/21 of the star contactor (K1) are utilized to activate the delta connection (K3).

Approvals:

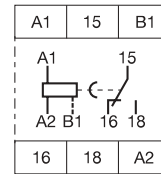
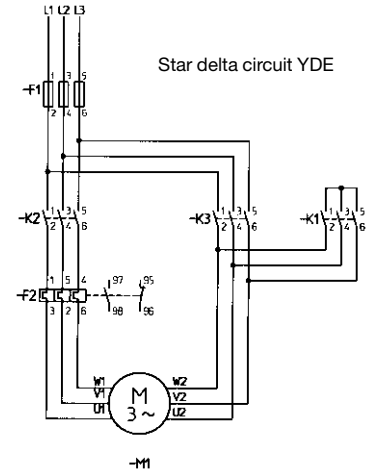

Diagram of powering circuit



Time ranges	Supply voltage	P/ N: E series Screw connection	P/ N: C series Spring connection
0.1...10 s	24 V AC/DC / 220...240 V AC	2 550 207 11	2 530 207 11
0.3...30 s	24 V AC/DC / 220...240 V AC	2 550 207 41	2 530 207 41
3...300 s	24 V AC/DC / 220...240 V AC	2 550 207 21	2 530 207 21
0.1...10 s	110...130 V AC	2 550 200 11	2 530 200 11
0.3...30 s	110...130 V AC	2 550 200 41	2 530 200 41
3...300 s	110...130 V AC	2 550 200 21	2 530 200 21

Technical Data

Input circuit

Supply voltage - power consumption	B1-A2	24 V AC/DC	-	1.0 VA / W
	A1-A2	110...130 V AC	-	2.0 VA
	A1-A2	240 V AC/DC	-	2.0 VA

Tolerance of the supply voltage -15 % ... +10 %

Supply voltage frequency 50...60 Hz

Duty time 100%

Timing circuit

Time ranges 0.1...10 s 0.3...30 s 3...300 s

Recovery time ≤ 500 ms

Repetitive accuracy (constant parameter) ≤ 1.0 %

Timing error within the tolerance of the supply voltage ≤ 0.5 %

Timing error within temperature range ≤ 0.1 % / °C

Star-delta changeover time 50 ms

Display of operational status

Supply voltage LED green

Output relay energized LED red

Output circuit 15-16/18 Relay, 1 SPDT contact

Rated voltage VDE 0100, IEC947-1 250 V

Switching voltage max. 240 V AC

Rated switching current AC 12 (resistive) 4 A (at 230 V)

Rated switching current AC 15 (inductive) 3 A (at 230 V)

Rated switching current DC 12 (resistive) 4 A (at 24 V)

Rated switching current DC 13 (inductive) 2 A (at 24 V)

Maximum mechanical life 30 x 10⁶ operations

Maximum electrical life (to AC 12 / 230 V / 4A) 1 x 10⁵ operations

Short-circuit proof, max. fuse rating 10 A / fast, operating class gL

Opening time ≤ 20 ms

General data

Rated impulse voltage withstand Vimp 4 kV

Operating temperature range -20°C ... +60°C

Storage temperature range -40°C ... +85°C

Installation position any

Mounting on DIN rail (EN 50022) Snap-on mounting/ screw mounting by adapter

Wire size, stranded with wire end ferrule 2 x 16 AWG (2 x 1.5 mm²)

Weight approx. 2.8 oz (80 g)

Dimensions (W x H x D) YDE 22.5 x 78 x 78.5 mm

YDC 22.5 x 104 x 83 mm

Accessories See Mechanical Outline page at end of section

See Accessories page at end of section

1 Function

= Star-delta changeover

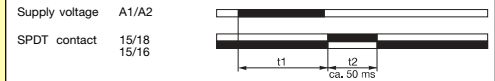

t1 = Start-up time
t2 = Changeover time

Control circuit diagram

